

Eine vom Bund und den Ländern
gemeinsam getragene Anstalt des
öffentlichen Rechts

Kolonnenstraße 30 B
D-10829 Berlin
Tel.: +49 30 78730-0
Fax: +49 30 78730-320
E-Mail: dibt@dibt.de
www.dibt.de

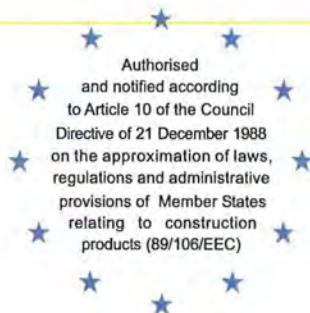

Mitglied der EOTA
Member of EOTA

European Technical Approval ETA-11/0189

English translation prepared by DIBt - Original version in German language

Handelsbezeichnung
Trade name

Derix Brettsperrholz
Derix Cross Laminated Timber

Zulassungsinhaber
Holder of approval

W. u. J. Derix GmbH & Co.
Dam 63
41372 Niederkrüchten
DEUTSCHLAND

Zulassungsgegenstand
und Verwendungszweck
*Generic type and use
of construction product*

Massives plattenförmiges Holzbauelement zur Verwendung als
tragendes Bauteil in Bauwerken
Solid wood slab element to be used as a structural element in buildings

Geltungsdauer:
Validity: vom
from
bis
to

10 June 2011
10 June 2016

Herstellwerke
Manufacturing plants

W. u. J. Derix GmbH & Co.
Dam 63
41372 Niederkrüchten
DEUTSCHLAND
Poppensieker & Derix GmbH & Co. KG
Industriestraße 24
49492 Westerkappeln
DEUTSCHLAND

Diese Zulassung umfasst
This Approval contains

22 Seiten einschließlich 6 Anhänge
22 pages including 6 annexes

I LEGAL BASES AND GENERAL CONDITIONS

- 1 This European technical approval is issued by Deutsches Institut für Bautechnik in accordance with:
 - Council Directive 89/106/EEC of 21 December 1988 on the approximation of laws, regulations and administrative provisions of Member States relating to construction products¹, modified by Council Directive 93/68/EEC² and Regulation (EC) N° 1882/2003 of the European Parliament and of the Council³;
 - Gesetz über das In-Verkehr-Bringen von und den freien Warenverkehr mit Bauprodukten zur Umsetzung der Richtlinie 89/106/EWG des Rates vom 21. Dezember 1988 zur Angleichung der Rechts- und Verwaltungsvorschriften der Mitgliedstaaten über Bauprodukte und anderer Rechtsakte der Europäischen Gemeinschaften (Bauproduktengesetz - BauPG) vom 28. April 1998⁴, as amended by law of 31 October 2006⁵;
 - Common Procedural Rules for Requesting, Preparing and the Granting of European technical approvals set out in the Annex to Commission Decision 94/23/EC⁶.
Deutsches Institut für Bautechnik is authorized to check whether the provisions of this European technical approval are met. Checking may take place in the manufacturing plants. Nevertheless, the responsibility for the conformity of the products to the European technical approval and for their fitness for the intended use remains with the holder of the European technical approval.
- 3 This European technical approval is not to be transferred to manufacturers or agents of manufacturers other than those indicated on page 1, or manufacturing plants other than those indicated on page 1 of this European technical approval.
- 4 This European technical approval may be withdrawn by Deutsches Institut für Bautechnik, in particular pursuant to information by the Commission according to Article 5(1) of Council Directive 89/106/EEC.
- 5 Reproduction of this European technical approval including transmission by electronic means shall be in full. However, partial reproduction can be made with the written consent of Deutsches Institut für Bautechnik. In this case partial reproduction has to be designated as such. Texts and drawings of advertising brochures shall not contradict or misuse the European technical approval.
- 6 The European technical approval is issued by the approval body in its official language. This version corresponds fully to the version circulated within EOTA. Translations into other languages have to be designated as such.

¹ Official Journal of the European Communities L 40, 11 February 1989, p. 12

² Official Journal of the European Communities L 220, 30 August 1993, p. 1

³ Official Journal of the European Union L 284, 31 October 2003, p. 25

⁴ *Bundesgesetzblatt Teil I 1998*, p. 812

⁵ *Bundesgesetzblatt Teil I 2006*, p. 2407, 2416

⁶ Official Journal of the European Communities L 17, 20 January 1994, p. 34

II SPECIFIC CONDITIONS OF THE EUROPEAN TECHNICAL APPROVAL

1 Definition of the product and intended use

1.1 Definition of the construction product

Derix Cross Laminated Timber is a cross laminated timber element made of softwood consisting of an odd number of 3 layers up to 11 layers. The lay-up of the cross laminated timber shall be symmetrical about its centre plane. The elements are plane.

Individual layers consist of parallel oriented lamellae made of strength graded boards or wood based panels. Wood based panel layers may be bonded to layers made of softwood lamellae or solid wood panels perpendicular (angle of 90°) to each other. The overall thickness of the layers consisting of wood based panels may not exceed 50 % of the element thickness.

In elements with at least five layers, two adjacent layers may be oriented with parallel grain direction. With the exception of the solid wood panels according to EN 13986⁷ it is not allowed to arrange wood based panels in two adjacent layers.

The principle structure of the cross laminated timber is shown in Annex 1, Figure 1 and Figure 2.

The application of chemical substances (wood preservatives and flame retardants) is not subject of the European technical approval.

Wood species are spruce, fir, pine and larch.

1.2 Intended use

The cross laminated timber is intended to be used as a structural or non structural element in buildings and timber structures. The cross laminated timber shall be subjected to static and quasi static actions only.

The elements are intended to be used in service classes 1 and 2 according to EN 1995-1-1⁸.

The provisions made in this European technical approval are based on an assumed intended working life of cross laminated timber of 50 years, provided that the conditions laid down in sections 4.2, 5.2 and 5.3 for the installation, packaging, transport, storage, use, maintenance and repair are met. The indications given on the working life cannot be interpreted as a guarantee given by the manufacturer or the Approval Body, but are regarded only as a means for selecting the appropriate product in relation to the expected, economically reasonable working life of the construction works.

2 Characteristics of the product and methods of verification

2.1 Characteristics of the product

2.1.1 General

Cross laminated timber and their layers correspond to the specifications given in Annexes 1 to 3 of this European technical approval. The material characteristics, dimensions and tolerances of the cross laminated timber not indicated in these Annexes are given in the technical documentation of the European technical approval.

⁷ EN 13986:2004 Wood-based panels for use in construction – Characteristics, evaluation of conformity and marking

⁸ EN 1995-1-1:200 + AC:2006 + A1:2008 Eurocode 5: Design of timber structures – Part 1-1: General – Common rules and rules for buildings

2.1.2 Boards

Specifications of the used boards are given in Annex 2. Boards are visually or machine strength graded. Only technically dried wood shall be used. The boards can be connected by finger joints according to EN 385⁹ in longitudinal direction. Butt joints are not permissible.

2.1.3 Wood based panels

For layers consisting of wood based panels oriented strand boards (OSB), plywood, laminated veneer lumber (LVL), and single-layered solid wood panels in each case according to EN 13986 and laminated veneer lumber (LVL) according to EN 14374¹⁰ or a European technical approval may be used.

Only wood based panels, which fulfil the requirements for the given service classes according to EN 1995-1-1, shall be used.

Only wood based panels which can be assigned to formaldehyde class E1 according to EN 13986 shall be used.

2.1.4 Adhesive

For gluing the cross laminated timber among each other and the wood-based panels as well as the finger joints of the individual boards an adhesive type 1 according to EN 301¹¹ is to be used. Specifications are deposited with Deutsches Institut für Bautechnik.

2.2 Mechanical resistance and stability

The specifications regarding mechanical resistance and stability are given in Annexes 2 to 6. Design of the elements shall be carried out according to EN 1995-1-1. Design also may be carried out according to corresponding national provisions that apply at the installation site of the certified object.

2.3 Behaviour in case of fire**Reaction to fire**

In accordance with Commission Decision 2003/43/EC the cross laminated timber elements covered by this European technical approval for use as wall, roof, ceiling and special construction components comply with Euroclass D-s2, d0 according to EN 13501-1¹². For the use as floor construction components they comply with Euroclass D_f-s1. The boundary conditions stated in the Commission Decision shall be followed for this classification.

The Decision of the European Commission might not apply if wood-based panels or other coverings are part of the element, depending on the coverings used and the boundary conditions affected.

Note:

A European reference fire scenario for façades has not been laid down. In some Member States, the classification of the cross laminated timber according to EN 13501-1 might not be sufficient for the use in façades. An additional assessment of the cross laminated timber according to national provisions (e.g. on the basis of a large scale test) might be necessary to comply with Member State regulations, until the existing European classification system has been completed.

⁹	EN 385:2001	Finger jointed structural timber - Performance requirements and minimum production requirements
¹⁰	EN 14374:2004	Timber structures – Structural laminated veneer lumber - Requirements
¹¹	EN 301:2006	Adhesives, phenolic and aminoplastic, for load-bearing timber structures – Classification and performance requirements
¹²	EN 13501-1:2007	Fire classification of construction products and building elements – Part 1: Classification using data from reaction to fire tests

2.4 Hygiene, health and the environment

A manufacturer's declaration has been submitted that no dangerous substances are used in the product regulated by this European technical approval.

Wood preservatives or flame retardants are not part of the European technical approval.

The class of formaldehyde is E1 according to EN 13986 with respect to cross laminated timber.

Note:

In addition to the specific clauses relating to dangerous substances contained in this European technical approval, there may be other requirements applicable to the products falling within its scope (e.g. transposed European legislation and national laws, regulations and administrative provisions). In order to meet the provisions of the Construction Products Directive, these requirements need also to be complied with, when and where they apply.

2.5 Methods of verification

The assessment of the fitness of the cross laminated timber for the intended use in relation to the requirements for mechanical resistance and stability, for safety in case of fire, for hygiene, health and the environment, for protection against noise, for energy economy and heat retention, as well as for durability in these fields has been made in compliance with the assessment rules for cross laminated timber agreed upon within EOTA.

3 Evaluation and attestation of conformity and CE marking

3.1 System of attestation of conformity

According to the Decision 97/176/EC¹³ of the European Commission for the product family system 1 of the attestation of conformity applies.

This system of attestation of conformity is defined as follows:

System 1: Certification of the conformity of the product by an approved certification body on the basis of:

- (a) Tasks for the manufacturer:
 - (1) factory production control;
 - (2) further testing of samples taken at the factory by the manufacturer in accordance with a prescribed test plan;
- (b) Tasks for the approved body:
 - (3) initial type-testing of the product;
 - (4) initial inspection of factory and of factory production control;
 - (5) continuous surveillance, assessment and approval of factory production control.

Note: Approved bodies are also referred to as "notified bodies".

¹³

Official Journal of the European Communities L 73/19 from 03/1997

3.2 Responsibilities

3.2.1 Tasks for the manufacturer

3.2.1.1 Factory production control

The manufacturer shall exercise permanent internal control of production. All the elements, requirements and provisions adopted by the manufacturer shall be documented in a systematic manner in the form of written policies and procedures, including records of results performed. This production control system shall insure that the product is in conformity with this European technical approval.

The manufacturer may only use constituent materials stated in the technical documentation of this European technical approval.

The factory production control shall be in accordance with the "Control plan relating to the European technical approval ETA-11/0189 issued on 10 June 2011" which is part of the technical documentation of this European technical approval. The control plan is laid down in the context of the factory production control system operated by the manufacturer and deposited with Deutsches Institut für Bautechnik.¹⁴

The results of factory production control shall be recorded and evaluated in accordance with the provisions of the control plan. The records include at least:

- designation of the product, basic materials and components;
- type of control or testing;
- date of manufacture of the product and date of testing of the product or basic materials or components;
- results of control and testing and, if appropriate, comparison with requirements;
- name and signature of person responsible for factory production control.

3.2.1.2 Other tasks for the manufacturer

The manufacturer shall, on the basis of a contract, involve a body which is approved for the tasks referred to in section 3.1 in order to undertake the actions laid down in section 3.2.2 For this purpose, the control plan referred to in sections 3.2.1.1 and 3.2.2 shall be handed over by the manufacturer to the approved body involved.

The manufacturer shall make a declaration of conformity, stating that the construction product is in conformity with the provisions of the European technical approval ETA-11/0189 issued on 10 June 2011. The declaration of conformity may only be given if the provisions of this ETA are met and the control plan is being followed.

3.2.2 Tasks for the approved bodies

The approved body shall perform the

- initial type-testing of the product,
- initial inspection of factory and of factory production control,
- continuous surveillance, assessment and approval of factory production

in accordance with the provisions laid down in the control plan.

The initial inspection of the factory shall include the inspection of the factory plant, the technical equipment and the qualification of the staff.

¹⁴

The "control plan" is a confidential part of the European technical approval and only handed over to the approved body involved in the procedure of attestation of conformity. See section 3.2.2.

The approved body shall retain the essential points of its actions referred to above and state the results obtained and conclusions drawn in a written report.

The approved certification body involved by the manufacturer shall issue an EC certificate of conformity of the product stating the conformity with the provisions of this European technical approval. The certificate of conformity can only be given if the provisions of this ETA are met and the control plan is being followed.

In cases where the provisions of the European technical approval and its control plan are no longer fulfilled the certification body shall withdraw the certificate of conformity and inform Deutsches Institut für Bautechnik without delay.

3.3 CE marking

The CE marking shall be affixed on the product itself, a label attached to it, the packaging or the accompanying commercial document.

The letters "CE" shall be followed by the identification number of the approved certification body and be accompanied by the following additional information:

- the name and address of the producer (legal entity responsible for the manufacture),
- the last two digits of the year in which the CE marking was affixed,
- the number of the EC certificate of conformity for the product,
- the number of the European technical approval,
- description of the element, showing its intended use,
- species of the wood used,
- number and arrangement of the layers,
- nominal thickness of the element,
- strength class of the wood of each layer,
- class of release of formaldehyde (if required),
- type and classification of the adhesive used

4 Assumptions under which the fitness of the product for the intended use was favourably assessed

4.1 Manufacturing

The cross laminated timber is manufactured in accordance with the provisions of this European technical approval using the automated manufacturing process as laid down in the technical documentation.

The layers shall be glued together to the required thickness of the cross laminated timber.

Pressing of the elements is executed with a pneumatic press with a flat pressure of 0.5 to 0.8 MPa. Details regarding the manufacturing process are deposited with Deutsches Institut für Bautechnik.

The boards may be connected by finger joints according to EN 385 in longitudinal direction. Wood-based panels may not be connected in longitudinal direction. Joints parallel to the longitudinal direction shall be taken into account.

The European technical approval is issued for the product on the basis of agreed data/information, deposited with Deutsches Institut für Bautechnik, which identifies the product that has been assessed and judged. Changes to the product or production process, which could result in this deposited data/information being incorrect, should be notified to Deutsches Institut für Bautechnik before the changes are introduced. Deutsches Institut für Bautechnik will decide whether or not such changes affect the approval and consequently the validity of the CE marking on the basis of the approval and if so whether further assessment or alterations to the approval shall be necessary.

4.2 Installation

4.2.1 Design of cross laminated timber elements

This European technical approval only applies to the manufacture and use of the cross laminated timber regulated here. Verification of stability of the buildings while using the cross laminated timber elements is not subject of this European technical approval.

Fitness for the intended use of the cross laminated timber is given under the following conditions:

- Design of the cross laminated timber elements is carried out under the responsibility of an engineer experienced in these elements.
- Design of the works provides a sufficient protection of the cross laminated timber elements.
- The cross laminated timber elements are installed correctly.

Design of the cross laminated timber elements can be performed according to EN 1995-1-1 taking into account the Annexes 2 to 6 of this European technical approval. Standards and regulations valid in the place of use shall be considered.

4.2.2 Installation of cross laminated timber elements

The manufacturer shall prepare assembling instructions in which the product-specific characteristics and important measures to be taken into consideration for assembling are described. The assembling instructions shall be available at every construction site.

The assembling of cross laminated timber elements shall be carried out by appropriately qualified personnel.

Cross laminated timber elements shall be protected against detrimental change of moisture.

5 Indications to the manufacturer

5.1 General

The manufacturer shall ensure that the requirements stated in clauses 1, 2 and 4 and the Annexes of this European technical approval are made known to those who are concerned during planning and execution of the works.

5.2 Recommendations on packaging, transport and storage

The cross laminated timber elements shall be protected during transport and storage against any damage and detrimental moisture effects. The manufacturer's instructions for packaging, transport and storage shall be observed.

European technical approval

ETA-11/0189

English translation prepared by DIBt

Page 9 of 22 | 10 June 2011

5.3 Use, maintenance, repair

The assessment of the fitness for use is based on the assumption that maintenance is not required during the assumed intended working life. In case of a severe damage of a cross laminated timber element immediate actions regarding the mechanical resistance and stability of the works shall be initiated. Should this situation arise replacement of the elements can be necessary.

Georg Feistel
Head of Department

beglaubigt:
Niebur

Construction of the wood members Derix Cross Laminated Timber (example)

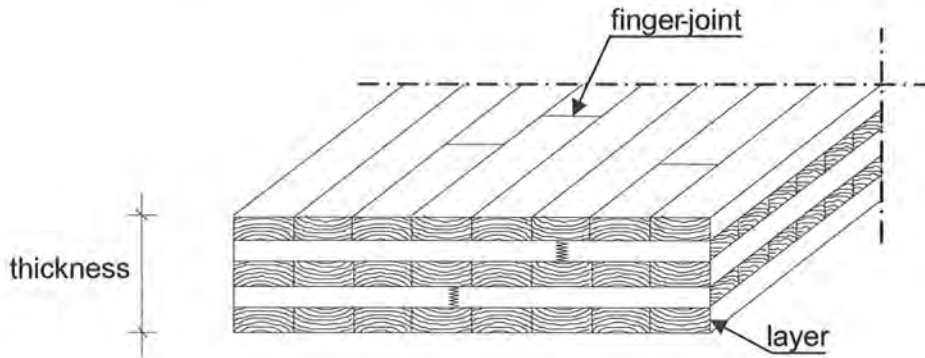

Figure 1: Principle structure of the cross laminated timber element (five layers)

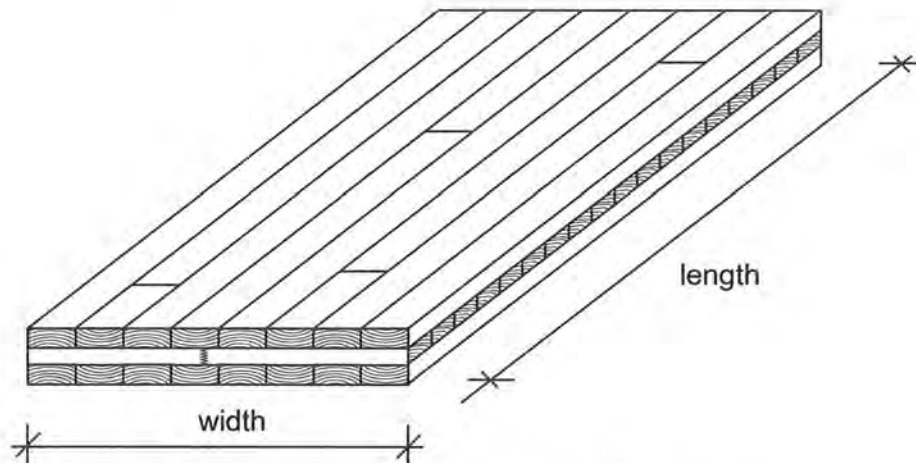

Figure 2: Cross laminated timber element (three layers)

Derix Cross Laminated Timber	Annex 1
Construction of the cross laminated timber	

Table 1: Dimensions and specifications of the elements

Characteristic	Specification
Cross laminated timber element	
Thickness	60 to 400 mm
Tolerance in thickness	± 2 mm if thickness ≤ 200 mm ± 3 mm if thickness > 200 mm
Width	≤ 3.50 m
Length	≤ 18.00 m
Number of layers	3 ≤ n ≤ 11
Number of consecutive layers having the same grain direction	≤ 2 for n ≥ 5
Maximum width of gaps between adjacent boards	
- in longitudinal layers	3 mm
- in cross layers	6 mm
Boards	
Material	Spruce, fir, pine, larch
Strength class according to EN 338 ¹⁵ resp EN 14081-1 ¹⁶	≥ C16 *)
Thickness	
- in longitudinal layers	15 to 45 mm
- in cross layers	15 to 40 mm
Width	80 to 260 mm
Ratio width to thickness of the cross-layers	≥ 4:1
Moisture of wood according to EN 13183-2 ¹⁷	8 ± 2; 9 ± 2, 10 ± 2; 11 ± 2, 12 ± 2 (in %) Within one cross laminated timber element only one of the specified moisture ranges shall be applied.
Finger joints	EN 385
Wood based panels	
Material	OSB, plywood, LVL and single-layered solid wood panels according to EN 13986 or a ETA and LVL according to EN 14374 or a ETA
Thickness	15 to 45 mm
Joints	Wood-based panels may not be connected in longitudinal direction. Joints parallel to the longitudinal direction shall be taken into account.
*) In each layer 10 % of a lower strength class may be used.	

¹⁵ EN 338:2009 Timber structures - Strength classes

¹⁶ EN 14081-1:2005 Timber structures. Strength graded structural timber with rectangular cross section. General requirements

¹⁷ EN 13183-2:2002 Moisture content of a piece of sawn timber - Part 2: Estimation by electrical resistance method

Derix Cross Laminated Timber	Annex 2
Dimensions and specifications of the cross laminated timber	

Table 2 Essential requirements of the cross laminated timber

ER	Requirement	Verification method	Class / Use category / Value
Mechanical resistance and stability			
For the calculation the characteristic strength and stiffness values of softwood according to EN 338 shall be used taking into consideration the definitions in Annex 2. Wood based-panels shall fulfil the requirements given in EN 13986, EN 14374 or a ETA and the technical class shall be declared. In addition the following values apply:			
1	Panel shear strength	Shear strength for the calculation with the gross cross section (5% fractile)	$f_{v,k}$ as given in Table 3
	Bending strength	Rolling shear strength (5% fractile)	$f_{R,k}$ 1.0 N/mm ²
		Rolling shear modulus (mean value)	$G_{R,mean}$ 50 N/mm ²
For references regarding the calculation see Annexes 4 to 6. National regulations might have to be followed.			
	Use of fasteners	According to EN 1995-1-1, for further details see Annex 5	
	Creep and duration of load	According to EN 1995-1-1	
	Dimensional stability	Moisture content during use shall not change to such an extent that adverse deformations can occur.	
Behaviour in case of fire			
Reaction to fire			
2	Solid wood panels except for floorings	Commission Decision 2003/43/EC	Euroclass D-s2, d0
	Floorings		Euroclass D _{fl} -s1
Resistance to fire			
	Charring rate only applies for tightly butted boards	EN 1995-1-2 ¹⁸	$\beta_0 = 0.65$ mm/min $\beta_n = 0.7$ mm/min
Hygiene, health and the environment			
3	Water vapour resistance factor μ	EN 10456 ¹⁹	no performance determined
	Release of formaldehyde	EN 13986 with respect to cross laminated timber	Class E1
Safety in use			
4	Slipperiness		no performance determined
	Impact resistance		no performance determined
Protection against noise			
5	Airbourne sound insul.		no performance determined
	Impact sound insulation		no performance determined
	Sound absorption		no performance determined
Energy economy and heat retention			
6	Thermal conductivity λ	EN ISO 10456	no performance determined
	Air tightness		no performance determined
	Thermal inertia c_p	EN ISO 10456	no performance determined
Durability			
-	Use only in service classes	EN 1995-1-1	1 and 2

¹⁸ EN 1995-1-2:2004 + AC:2009 Eurocode 5: Design of timber structures – Part 1-2: General –Structural fire design
¹⁹ EN ISO 10456:2007 + AC:2009 Building materials and products – Hygrothermal properties – Tabulated design values and procedures for determining declared and design thermal values

Derix Cross Laminated Timber	Annex 3/1
Essential requirements of the cross laminated timber	

Table 3: Characteristic shear strength $f_{v,k}$ calculated with the gross cross section (for mechanical actions in plane of the cross laminated timber)

Element Thickness in mm	Number of layers	Thickness of individual layers in mm (written in bold characters for longitudinal layers)										$f_{v,k}^{1)}$ in N/mm ²
63	3	21	21	21								2.5
85	3	32	21	32								1.9
96	3	32	32	32								1.9
112	3	40	32	40								1.7
105	5	21	21	21	21	21						3.0
147	5	35	21	35	21	35						2.2
162	5	40	21	40	21	40						2.1
184	5	40	32	40	32	40						2.0
63	3	21	21	21								2.5
85	3	32	21	32								1.9
96	3	32	32	32								1.9
101	3	40	21	40								1.7
112	3	40	32	40								1.7
120	3	40	40	40								1.8
105	5	21	21	21	21	21						3.0
138	5	32	21	32	21	32						2.3
162	5	40	21	40	21	40						2.1
184	5	40	32	40	32	40						2.0
200	5	40	40	40	40	40						2.1
147	7	21	21	21	21	21	21	21				3.3
191	7	32	21	32	21	32	21	32				2.5
213	7	32	32	32	21	32	32	32				2.5
223	7	40	21	40	21	40	21	40				2.2
234	7	40	21	40	32	40	21	40				2.2
256	7	40	32	40	32	40	32	40				2.2
280	7	40	40	40	40	40	40	40				2.3
244	9	32	21	32	21	32	21	32	21	32		2.7
260	9	40	21	32	21	32	21	32	21	40		2.3
284	9	40	21	40	21	40	21	40	21	40		2.3

Derix Cross Laminated Timber	Annex 3/2
Essential requirements of the cross laminated timber	

Table 3 (continued)

Element Thickness in mm	Number of layers	Thickness of individual layers in mm (written in bold characters for longitudinal layers)											$f_{v,k}$ ¹⁾ in N/mm ²
288	9	32	32	32	32	32	32	32	32	32			2.6
304	9	40	32	32	32	32	32	32	32	40			2.2
320	9	40	32	40	32	32	32	40	32	40			2.3
328	9	40	32	40	32	40	32	40	32	40			2.3
360	9	40	40	40	40	40	40	40	40	40			2.4
378	11	40	21	40	32	40	32	40	32	40	21	40	2.4
400	11	40	32	40	32	40	32	40	32	40	32	40	2.4
224	7	32	32	32	32	32	32	32					1.7
218	7	40	32	21	32	21	32	40					1.3
234	7	40	40	21	32	21	40	40					1.3
256	7	40	40	32	32	32	40	40					1.4
264	7	40	40	32	40	32	40	40					1.4
272	7	40	40	40	32	40	40	40					1.5
280	7	40	40	40	40	40	40	40					1.5

¹⁾ Values apply to a minimum board width of
120 mm for a board thickness of 21 mm
140 mm for a board thickness of 32 mm
160 mm for a board thickness of 40 mm

Derix Cross Laminated Timber	Annex 3/3
Essential requirements of the cross laminated timber	

1 Mechanical actions perpendicular to the plane of the element

Stress distribution within the element shall be calculated taking into account the shear deformation of the cross layers.

Stress distribution within the element shall be calculated taking into account the shear deformation of the cross layers.

For simply supported cross laminated timber elements with up to 5 layers the stress distribution may be calculated according to EN 1995-1-1 as mechanically jointed beam where the value s_i/K_i is substituted by $\bar{h}_i / (G_R \cdot b)$

with \bar{h}_i = thickness of the cross layer
 $G_R = 50 \text{ N/mm}^2$ shear modulus of the cross layer
 b = width of the cross layer.

(Design according to the theory of flexible bonded beams see Annex 6)

For cross laminated timber with more than 5 layers numerical solutions shall be used offered by computer programs taking into account the shear deformation of the cross layers.

For the design of cross laminated timber the characteristic strength and stiffness values shall be taken from Annex 3.

For the bending design only the stresses at the edges of the boards are decisive.

For the calculation of the cross-section values according Annex 6 the boards and wood-based panels in load-bearing direction may be taken into account.

For the verification of the bending strength the design bending strength value of a layer of boards may be multiplied by a system strength factor k_f :

$$k_f = \min \begin{cases} 1 + 0,025 \cdot n \\ 1,2 \end{cases}$$

with n = number of boards within a layer

Tension loads perpendicular to the plane of the element shall be avoided.

2 Mechanical actions in plane of the cross laminated timber

Stress distribution within the element shall be calculated by taking into account only the boards which are oriented in the direction of the actions.

Shear stresses may be calculated with the total thickness of the element.

For the design of cross laminated timber elements made of layers of softwood the characteristic strength and stiffness values of the layers of softwood shall be taken from Annex 3.

For the design of cross laminated timber elements with layers of wood-based panels either the characteristic strength and stiffness values of the layers of softwood shall be used or the corresponding values of the wood-based panels may be taken into account.

For the verification of the bending strength the design bending strength value of a layer of boards may be multiplied by a system strength factor k_f :

$$k_f = \min \begin{cases} 1 + 0,025 \cdot n \\ 1,2 \end{cases}$$

with n = number of longitudinal layers.

Derix Cross Laminated Timber	Annex 4
Design of the cross laminated timber	

1 General

The design rules given in this section amend the design rules for connections given in EN 1995-1-1. Plane sides are the surfaces of the element parallel to the plane of the element, narrow sides are the surfaces perpendicular to the plane sides of the element.

The indications of the connectors in the plane sides only apply to outer layer made of softwood. Connectors in the narrow sides of wood-based panel are not permissible.

1.1 Perpendicular to the axis loaded dowel type fasteners

1.1.1 Joints in the plane side of cross laminated timber

Embedding strength:

For nails, self-tapping screws, dowels and bolts in the plane side of cross laminated timber the embedding strength of solid timber may be used, depending on the characteristic density of the laminations of the cross laminated timber and on the angle between force and grain direction of the outer layer.

The following conditions shall be fulfilled:

- Diameter of nails $d \geq 4$ mm
- Diameter of self-tapping screws $d \geq 6$ mm

Effective number of fasteners:

The effective number of fasteners n_{ef} for outer layers with a thickness ≤ 40 mm shall be taken from equation (1).

$$n_{ef} = n \quad \text{with } n \text{ number of fasters within one row} \quad (1)$$

For outer layers with a thickness > 40 mm the effective number of fasteners n_{ef} according to EC 5 (8.3.3.1) shall be used.

Minimum spacings, edge and end distances:

Minimum spacings, edge and end distances and angle α between the force and the grain direction of the outer layers as defined in Figure 4 are given in Table 4.

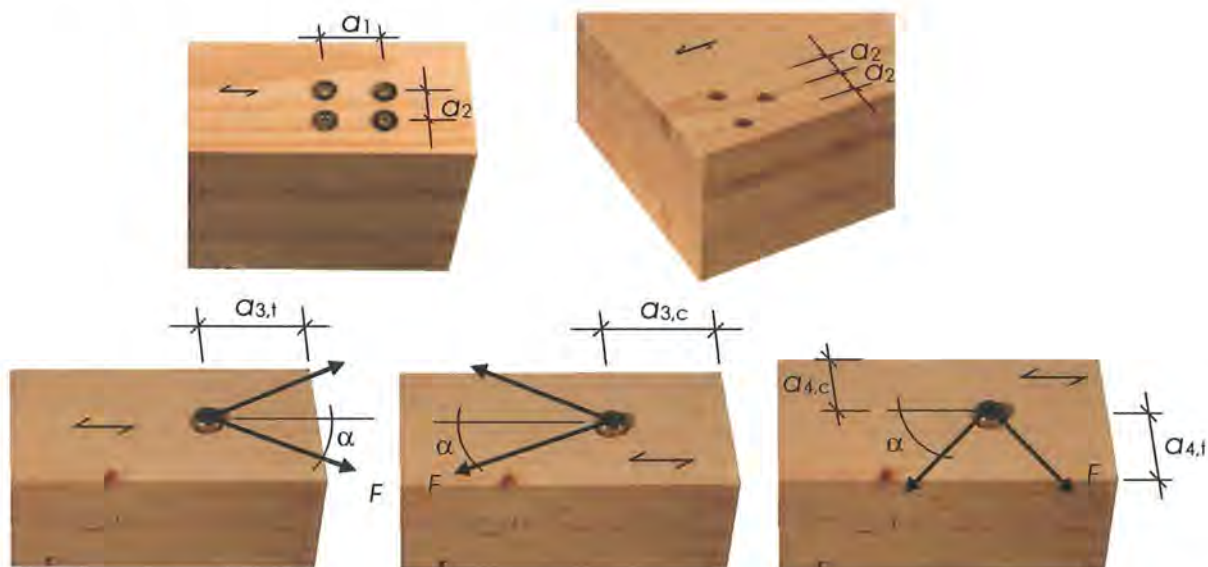

Figure 4: Definitions of minimum spacings, edge and end distances for laterally loaded dowel-type fasteners in the plane side of cross laminated timber

Derix Cross Laminated Timber	Annex 5/1
Design of connectors	

Table 4: Definitions of minimum spacings, edge and end distances in the plane side of cross laminated timber elements

	a_1	$a_{3,t}$	$a_{3,c}$	a_2	$a_{4,t}$	$a_{4,c}$
Nails	$(3+3 \cos \alpha) d$	$(7+3 \cos \alpha) d$	$6 d$	$3 d$	$(3+4 \sin \alpha) d$	$3 d$
Self-tapping screws	$4 d$	$6 d$	$6 d$	$2.5 d$	$6 d$	$2.5 d$
Dowels	$(3+2 \cos \alpha) d$	$5 d$	$\max \begin{cases} 4 d \cdot \sin \alpha \\ 3 d \end{cases}$	$3 d$	$3 d$	$3 d$
Bolts	$\max \begin{cases} (3+2 \cos \alpha) d \\ 4 d \end{cases}$	$5 d$	$4 d$	$4 d$	$3 d$	$3 d$

1.1.2 Joints in the narrow side of cross laminated timber

Embedding strength:

The characteristic embedding strength for self-tapping screws with a diameter $d \geq 8$ mm in the narrow sides of cross laminated timber may be calculated according to equation (2).

$$f_{h,k} = 20d^{0.5} \quad \text{in N/mm}^2 \quad (2)$$

Where

d = Nominal diameter of the self-tapping screws in mm

For actions perpendicular to the plane side of the cross laminated timber the possibility of splitting caused by the tension force component perpendicular to the grain, shall be taken into account. Connections with ratios $h_e/h < 0.7$ should be reinforced with fully threaded screws (see example in Figure 5).

Where

h_e = Loaded edge distance to the most distant fastener

h = Thickness of the cross laminated timber element

Derix Cross Laminated Timber	Annex 5/2
Design of connectors	

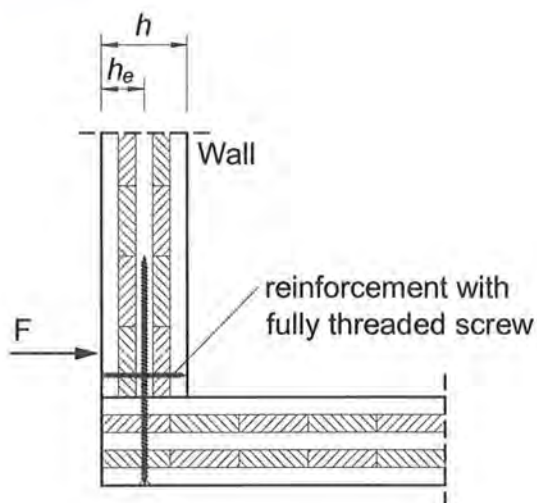

Figure 5: Reinforcement of a cross laminated timber wall with fully threaded screws

Effective number of fasteners:

The effective number of fasteners n_{ef} according to EC 5 (8.3.3.1) may be used.

Minimum spacings, edge and end distances:

Minimum spacings, edge and end distances as defined in Figure 6 and further requirements for connections with self-tapping screws in the narrow side of cross laminated timber are given in Table 5 and Table 6.

Derix Cross Laminated Timber	Annex 5/3
Design of connectors	

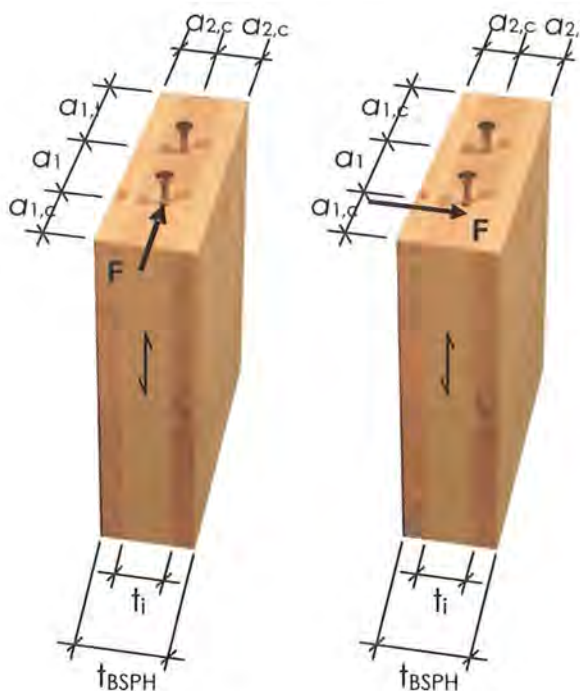

Figure 6: Definitions of minimum spacings, edge and end distances for laterally loaded dowel-type fasteners in the narrow side of cross laminated timber

Table 5: Definitions of minimum spacings, edge and end distances in the narrow side of cross laminated timber element

	a_1	$a_{3,l}$	$a_{3,c}$	a_2	$a_{4,l}$	$a_{4,c}$
Self-tapping screws	$10 d$	$12 d$	$7 d$	$3 d$	$6 d$	$3 d$

Table 6: Requirements for joints in the narrow side of cross laminated timber

	Minimum thickness of the relevant layer t_i in mm	Minimum thickness of the cross laminated timber t_{BSPH} in mm	Minimum penetration length of the fastener t_1 or t_2 in mm ^{a)}
Self-tapping screws	$d > 8 \text{ mm}: 3 \cdot d$ $d \leq 8 \text{ mm}: 2 \cdot d$	$10 \cdot d$	$10 \cdot d$
^{a)} t_1 Minimum penetration length of the fastener in side members t_2 Minimum penetration length of the fastener in middle members			

Derix Cross Laminated Timber	Annex 5/4
Design of connectors	

1.2 Axially loaded dowel type fasteners

1.2.1 Threaded nails

The characteristic withdrawal capacity for threaded nails in the plane sides of cross laminated timber may be calculated according equation (3).

$$R_{ax,k} = 14 d^{0.6} \cdot \ell_{ef} \quad \text{in N} \quad (3)$$

Where

d = Outer diameter of the threaded part

ℓ_{ef} = Penetration length of the threaded part

The following conditions should be fulfilled:

- at least two nails in a connection
- diameter of the threaded part $d \geq 4$ mm
- penetration length of the threaded part $\ell_{ef} \geq 8 d$
- characteristic point side withdrawal parameter $f_{ax,k} \geq 50 \cdot 10^{-6} \cdot \rho_k^2$
(value corresponds to load-bearing capacity class 3 in DIN 1052:2008-12)

with ρ_k = characteristic value of density (kg/m^3)

- Self tapping screws

1.2.2 Self tapping screws

Withdrawal capacity:

The characteristic withdrawal capacity for self tapping screws in the plane sides or in the narrow sides of cross laminated timber may be calculated according equation (4).

$$R_{ax,k} = \sum_{i=1}^n f_{ax,i,k} \cdot \ell_{ef,i} \cdot d \quad (4)$$

Where

d = Outer diameter of the threaded part, with $d \geq 6$ mm for screws in the plane sides of cross laminated timber and $d \geq 8$ mm for screws in the narrow sides of cross laminated timber

$f_{ax,i,k}$ = Characteristic withdrawal strength of layer i depending on the characteristic density $\rho_{k,i}$ and the angle α_i between screw axis and grain direction of layer i

$\ell_{ef,i}$ = Penetration length of the threaded part in layer i

n = Number of penetrated layers

Derix Cross Laminated Timber	Annex 5/5
Design of connectors	

The following conditions should be fulfilled:

- Penetration length of the threaded part $l_{ef,t} \geq 4 d$

For the design of axially loaded screws in cross laminated timber only threaded parts with an angle $\alpha \geq 30^\circ$ between screw axis and grain direction may be taken into account.

Screws oriented parallel to the plane side of the cross laminated timber should be completely arranged within one layer. The outer diameter of the threaded part should not exceed the thickness of the layer the screw is arranged in.

The characteristic pull-through strength of the screw head for solid timber may be used, depending on the characteristic density of the lamination at the head side of the screw.

1.3 Connections with split ring connectors and toothed-plate connectors

The characteristic value of the load-bearing capacity of split ring connectors and toothed-plate connectors in the plane sides of cross laminated timber may be calculated according to EN 1995-1-1.

Split ring connectors and toothed-plate connectors may neither be arranged in the plane sides of wood based panels nor in the narrow sides of Derix Cross Laminated Timber members containing wood-based panels.

For split ring connectors in the narrow sides of cross laminated timber the regulations for connections with split ring connectors in the end grain may be applied.

Toothed-plate connectors in the narrow sides of cross laminated timber shall not be taken into consideration as load-bearing.

Toothed-plate connectors in the narrow sides of cross laminated timber shall not be taken into consideration as load-bearing.

Derix Cross Laminated Timber	Annex 5/6
Design of connections with metal fasteners	

Design according to the theory of flexible bonded beams

The calculation of elements with up to five layers can be performed using the theory of flexible bonded beams as described in EN 1995-1-1.

To consider deformations due to shear the factor s/K_1 according to the standard is substituted by the factor $\bar{h}_i/(G_R \cdot b)$.

The effective moment of inertia is calculated by:

$$I_{ef} = \sum_{i=1}^3 (I_i + \gamma_i \cdot A_i \cdot a_i^2) \quad \text{with} \quad A_i = b_i \cdot h_i; \quad I_i = \frac{b_i \cdot h_i^3}{12}$$

$$\gamma_1 = \frac{1}{1 + \frac{\pi^2 \cdot E_0 \cdot A_1 \cdot \bar{h}_1}{G_R \cdot b \cdot l^2}}; \quad \gamma_2 = 1; \quad \gamma_3 = \frac{1}{1 + \frac{\pi^2 \cdot E_0 \cdot A_3 \cdot \bar{h}_2}{G_R \cdot b \cdot l^2}}$$

$$a_1 = \left(\frac{h_1}{2} + \bar{h}_1 + \frac{h_2}{2} \right) - a_2; \quad a_3 = \left(\frac{h_2}{2} + \bar{h}_2 + \frac{h_3}{2} \right) + a_2$$

$$a_2 = \frac{\gamma_1 \cdot A_1 \cdot \left(\frac{h_1}{2} + \bar{h}_1 + \frac{h_2}{2} \right) - \gamma_3 \cdot A_3 \cdot \left(\frac{h_2}{2} + \bar{h}_2 + \frac{h_3}{2} \right)}{\sum_{i=1}^3 (\gamma_i \cdot A_i)}$$

The verification of the bending performance is done by determination of the bending stress at the boundary of the boards. The bending stress in the middle of the boards may remain unconsidered.

$$\sigma_{m,r,i,d} = \pm \frac{M_d}{I_{ef}} \cdot \left(\gamma_i \cdot a_i + \frac{h_i}{2} \right) \leq f_{m,d}$$

The verification of the shear performance is done by determination of the shear stress in the decisive plane:

$$\tau_{v,d} = \frac{V_d \cdot \gamma_i \cdot S_i}{I_{ef} \cdot b} \leq f_{R,d}$$

Legend:

h_{tot} = thickness of the whole element [mm]

h_i = thickness of the layer i parallel to the direction of load transfer [mm]

\bar{h}_i = thickness of the layer i perpendicular to the direction of load transfer [mm]

b = width of the element [mm]

n = number of layers

l = span width [mm]

I_{ef} = effective moment of inertia [Nmm²]

G_R = rolling shear modulus [N/mm²]

E_0 = modulus of elasticity parallel to the grain of the boards [N/mm²]

Derix Cross Laminated Timber	Annex 6
Design according to the theory of flexible bonded beams	